

Anti Blowout Grip Ring

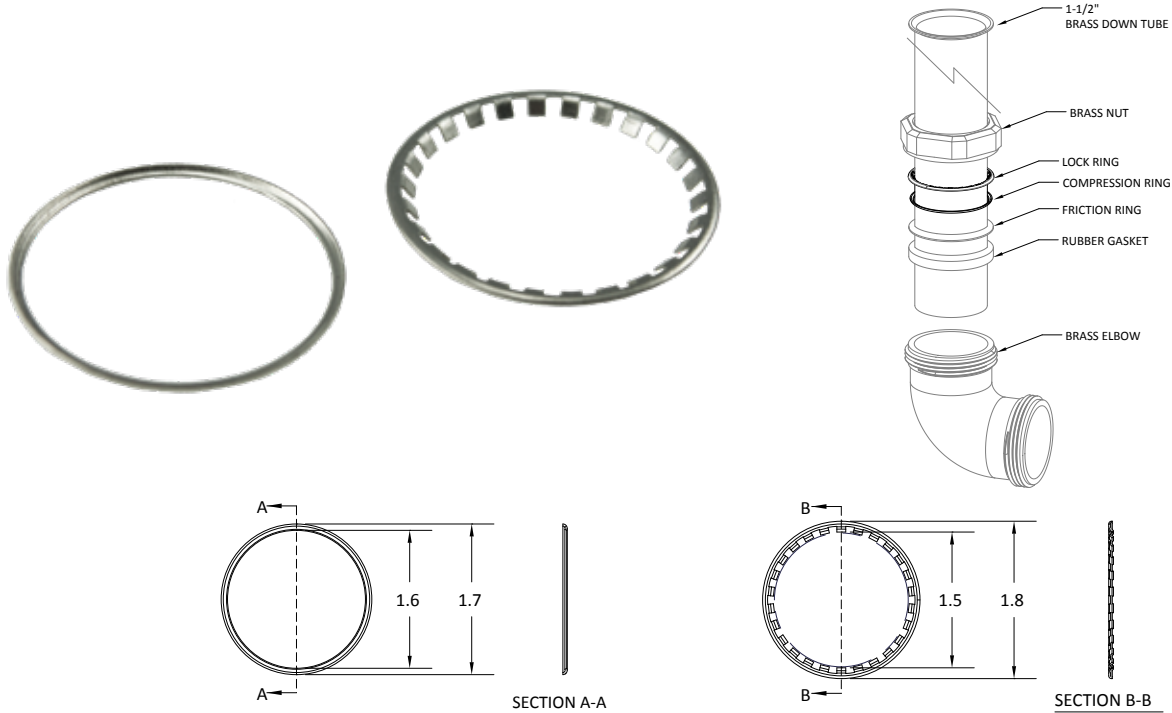

Part No. 100321

► Description

I-CON's Anti Blowout Grip Ring is designed to reduce blowout failures by increasing the holding force of a common slip joint. The two ring assembly is comprised of a lock ring with 26 teeth that bite and lock into the down tube when compressed by the compression ring. *Note: Anti Blowout Grip Rings are packaged (12) ring sets per pack.*

Specifications

- Made of stainless steel for increased strength and corrosion resistance.
- Designed for use on chrome plated, raw brass and all scratch threaded 1-1/2" vacuum breaker tubes.

► Accessories

See Accessories Section of the I-CON catalog or contact our Customer Service Team for details.



 **WARNING:** Cancer and Reproductive Harm - www.P65Warnings.ca.gov

This space is for Architect/Engineer approval

The information contained in this document is subject to change without notice.