

Wireless ENVISAGE® Signal Repeaters

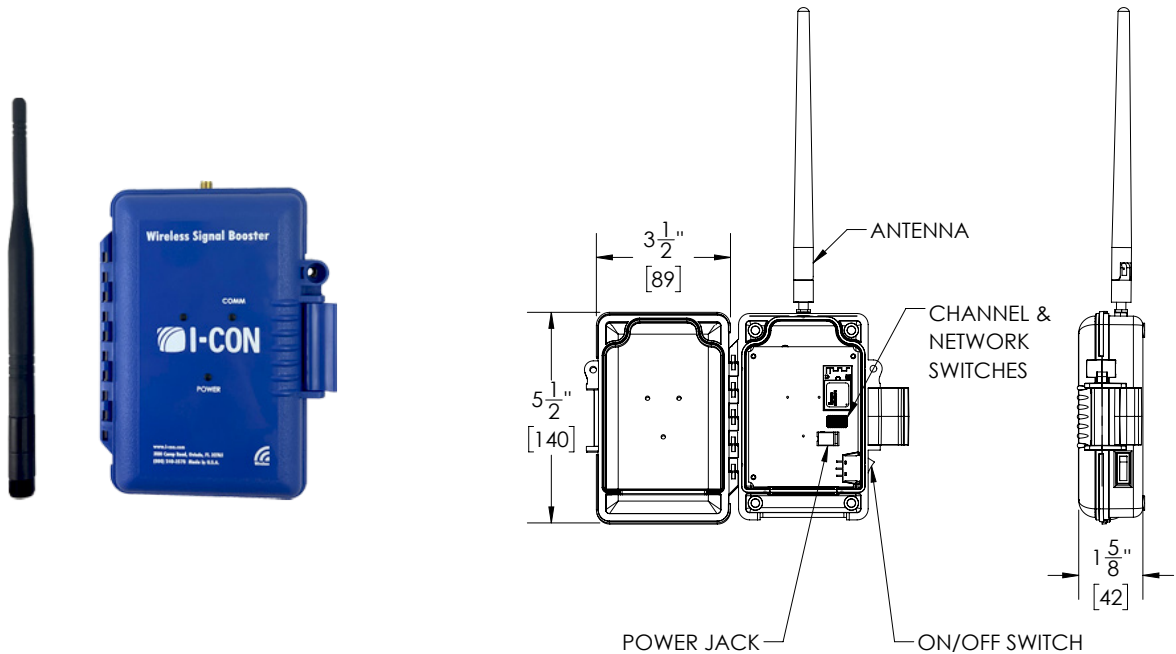

Part No. 102062

► **Description**

Wireless ENVISAGE® Signal Repeater.

► **Features**

- Requires 100960 5VDC Transformer
- LED indication of communication status
- Operates in the 2.4GHz frequency band
- Secure 128-bit AES encryption
- Automatic network formation
- Multiple networks can be created without interfering with each other
- Will not interfere with other wireless systems such as Wi-Fi or 2-way radios

► **Accessories**

See Accessories Section of the I-CON catalog or contact our Customer Service Team for details.



Recommended Specification

I-CON 102062 Wireless ENVISAGE® Signal Repeater allows for wireless ENVISAGE® communication signals to travel further. The signal repeater takes in the signal emitted by an I-CON ENVISAGE® Network Interface and retransmit it so that the signal can travel further.

 **WARNING:** Cancer and Reproductive Harm - www.P65Warnings.ca.gov

This space is for Architect/Engineer approval

The information contained in this document is subject to change without notice.