

COBALT® Exposed Side Sensor Flush Valve Exploded View

Part No. 103582 : 3000 : A

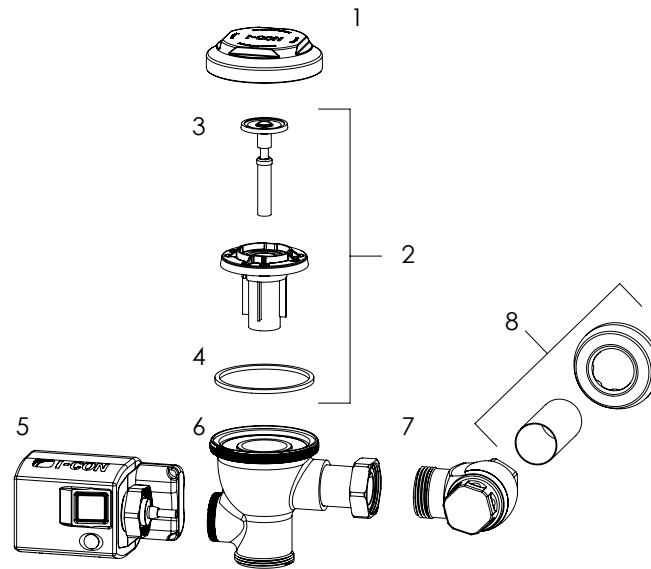

Label	Part Variant	Part Number	Description
1	-	100692	I-CON Cap, Chrome-Plated Brass
2	A	101427 : 0.125	ProLAST® Manual Rebuild Kit, Urinal - 0.125 gpf / 0.5 Lpf
2	B	101427 : 0.25	ProLAST® Manual Rebuild Kit, Urinal - 0.25 gpf / 0.9 Lpf
2	C	101427 : 0.5	ProLAST® Manual Rebuild Kit, Urinal - 0.5 gpf / 1.9 Lpf
2	D	101427 : 1.0	ProLAST® Manual Rebuild Kit, Urinal - 1.0 gpf / 3.8 Lpf
2	E	101427 : 1.1	ProLAST® Manual Rebuild Kit, Water Closet - 1.1 gpf / 4.2 Lpf
2	F	101427 : 1.28	ProLAST® Manual Rebuild Kit, Water Closet - 1.28 gpf / 4.8 Lpf
2	G	101427 : 1.6	ProLAST® Manual Rebuild Kit, Water Closet - 1.6 gpf / 6.0 Lpf
2	H	101427 : 2.4	ProLAST® Manual Rebuild Kit, Water Closet - 2.4 gpf / 9.0 Lpf
2	I	101427 : 3.5	ProLAST® Manual Rebuild Kit, Water Closet - 3.5 gpf / 13.2 Lpf
3	-	100989	Trip Mechanism
4	-	100999	Square-Profile O-Ring
5	-	103557	Side-Mount Sensor Actuator
6	-	101063	Valve Body - Chrome-Plated Brass
7	A	100993 : 1" : CP Brass	1" (25mm) Control Stop - Screwdriver Stop, Chrome-Plated Brass
7	B	100993 : 3/4" : CP Brass	3/4" (19mm) Control Stop - Screwdriver Stop, Chrome-Plated Brass
8	A	102548	1" (25mm) Sweat Solder Kit - 6" Tube Cover, Wall Flange with Set Screw, and Threaded Adapter
8	B	102549	3/4" (19mm) Sweat Solder Kit - 4" Tube Cover, Wall Flange with Set Screw, and Threaded Adapter