

EXPOSED SENSOR FLUSH VALVES

TOP EXPOSED

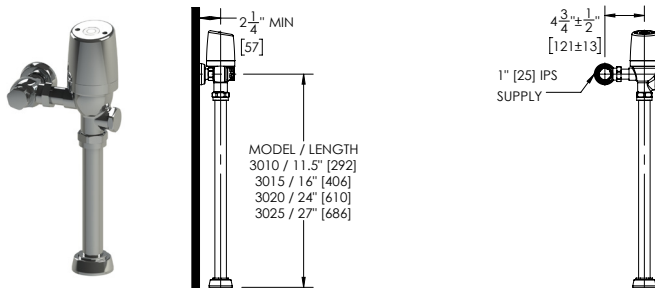

URINAL EXPOSED

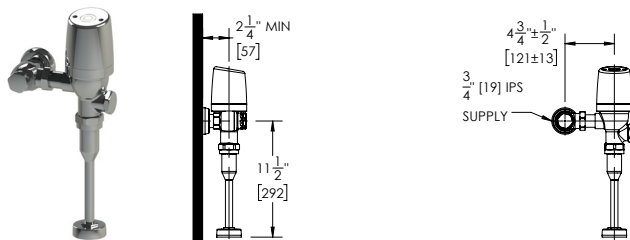

REAR EXPOSED

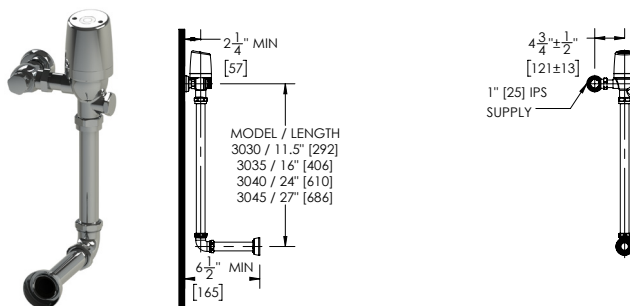

TOOLS NEEDED

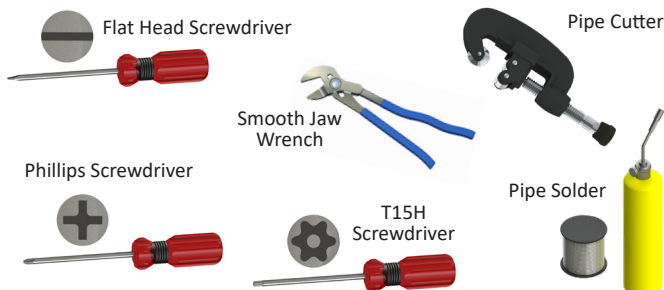

PRIOR TO INSTALLATION

- All plumbing should be installed according to applicable state and local codes and regulations.
- Before installation of the I-CON flush valve, ensure the water closet or urinal fixture, drain line and water supply line are properly installed.
- Water supply lines must be sized to allow for appropriate water flow for each fixture.
- Flush all water supply lines of any debris before making connections.
- Do not use pipe sealant or plumbing grease on any components or couplings, with the exception of the control stop inlet.
- A smooth jaw or strap wrench should be used for installation to prevent damage to the finish of the I-CON flush valve and components.

The I-CON flush valve is designed to operate at water pressures ranging from 15 to 100psi (103 to 689kPa). The fixture type determines the minimum pressure required for the valve. Most low-consumption water closets are designed to operate with a minimum flowing water pressure of 25psi (172kPa). Many building codes and the ASME A112.19.2 standard state maximum static water pressure as 80 psi.

LIMITED WARRANTY

I-CON Systems (I-CON) warrants that its commercial manufactured products are made of first-class materials, are free from defects, and are made to withstand normal use when installed properly. Products have the following warranty periods: 3 years for COBALT®, COBALT Pro®, and COBALT Connect® faucets and flush valves and I-CON EDGE® gateways. 1 year for all other products and decorative finishes. The warranty period begins on the date of purchase.

Products should be sent to I-CON at the customer's expense. I-CON will take a reasonable amount of time to determine if the product is defective and whether it will be repaired or replaced. During the warranty period, items will either be (1) repaired at no charge using new replacement parts or (2) replaced with either a new similar product or one manufactured from new or serviceable used parts that are at minimum a functional equivalent to the original. The course of action will be determined at I-CON's discretion. Replacement products that are installed according to the instructions provided by I-CON will assume the remaining warranty of the original product. The limited warranty is only applicable to the product's materials and workmanship. No claims for labor, transportation, or other incidental or consequential costs will be allowed. No extended warranties are available. THE SOLE AND EXCLUSIVE REMEDY FOR ANY DEFECTIVE PRODUCT IS LIMITED TO REPAIRING OR REPLACING THE DEFECTIVE PRODUCT. Before installing and using products, the purchaser is responsible for determining the products' suitability and assumes all risks and liabilities related to the product.

This warranty only applies to persons and organizations that purchase I-CON products directly from I-CON or an authorized I-CON representative for the purpose of resale. This warranty does not apply to the life of batteries or other consumables.

**OPTIONAL SWEAT SOLDER THREADED ADAPTER
INSTALLATION (FOR WATER SUPPLY LINES THAT
DO NOT HAVE MALE THREADS)**

Step 1

Measure distance from finished wall to centerline of fixture spud. Cut water supply pipe 1-1/4" (32mm) shorter than this measurement. Chamfer then deburr inner and outer diameter of water supply pipe.

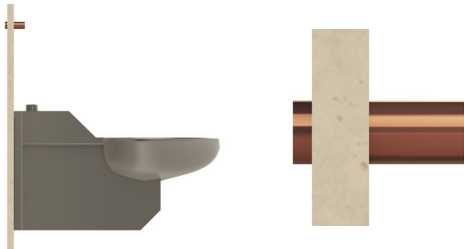

Step 2

Slide threaded adapter onto water supply pipe. Ensure full insertion.



Step 3

Sweat solder threaded adapter to water supply pipe.



**WALL ESCUTCHEON, SUPPLY COVER TUBE AND
CONTROL STOP INSTALLATION**

Step 1

Measure distance from finished wall to first thread of threaded adapter. Cut supply tube cover to measured length.

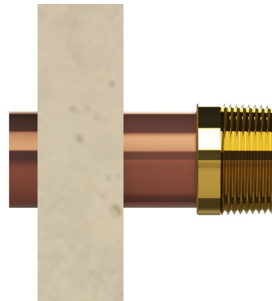

Step 2

Slide wall escutcheon over supply tube cover. Slide assembly over water supply pipe. Ensure wall escutcheon and supply tube cover rests flush against wall.

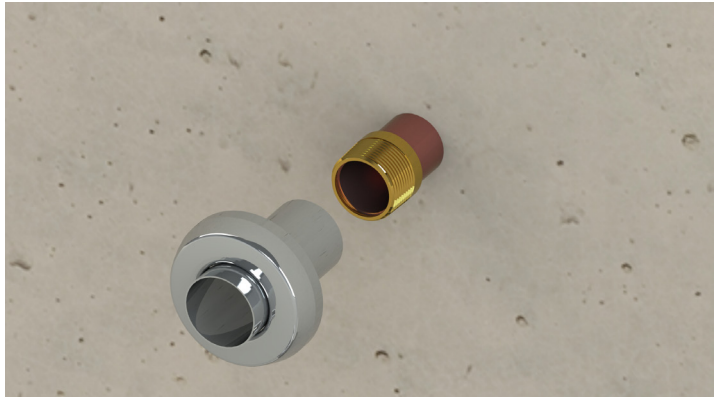

Step 3

Apply sealing compound to threaded adapter. Tighten control stop onto threaded adapter using a smooth jaw wrench.

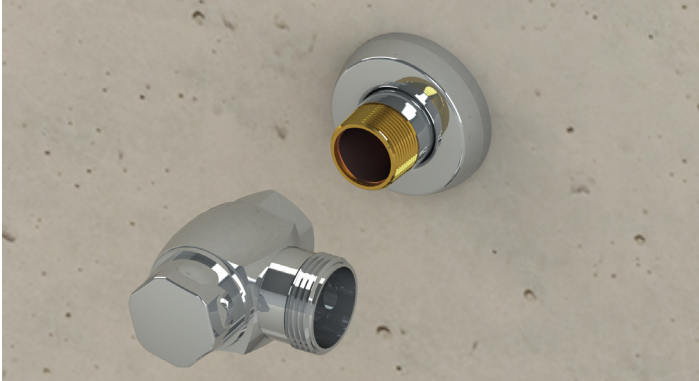

Step 4

Unscrew control stop cap. Turn adjustment screw **CLOCKWISE** to ensure control stop is closed. Turn on water supply and check for leaks.

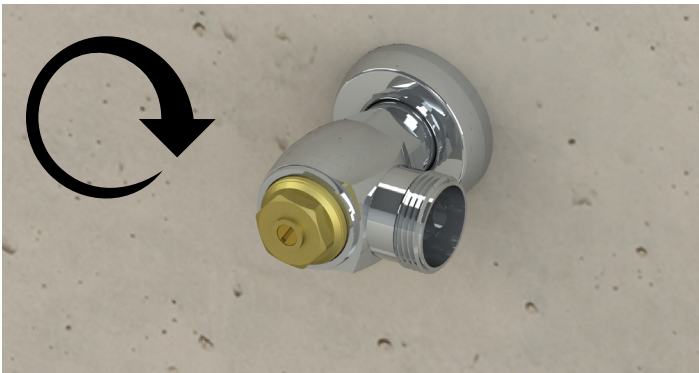

FLUSHING SUPPLY LINE

Step 1

Turn adjustment screw **COUNTERCLOCKWISE** to open control stop. Flush debris into bucket.

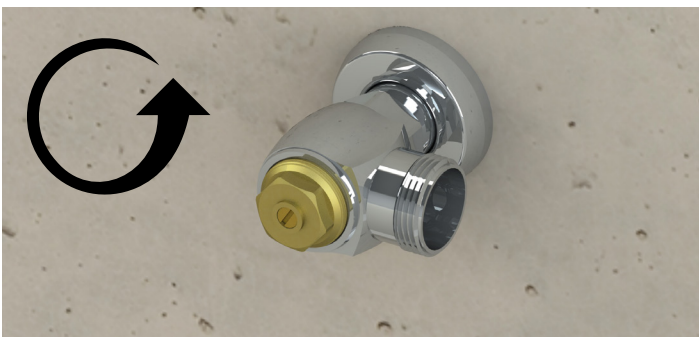

Step 2

Turn adjustment screw **CLOCKWISE** to close control stop.



FLUSH VALVE & VACUUM BREAKER INSTALLATION

Step 1

Install actuator cover on flush valve body.



Step 2

Lubricate tailpiece O-ring with water. Insert flush valve tailpiece into control stop.

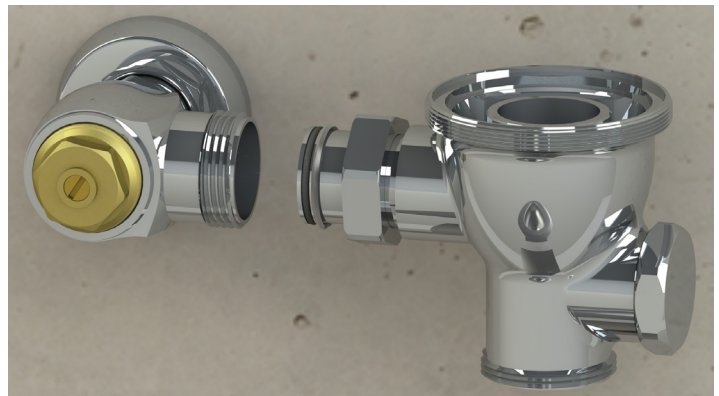

Step 3

Assemble vacuum breaker tube and spud escutcheon assemblies as shown. **NOTE:** The vacuum breaker tube may need to be cut to fit properly. If using scored vacuum breaker, always cut from scored end and leave at least 1-1/4" (32mm) of scoring. See chart below.

Step 4

Ensure flush valve is properly aligned with fixture and vacuum breaker tube. Tighten connections by hand.



Step 5

Once properly aligned, tighten connections with a smooth jaw wrench.



BATTERY INSTALLATION

Step 1

Remove screws from top of control module assembly. Remove cover.

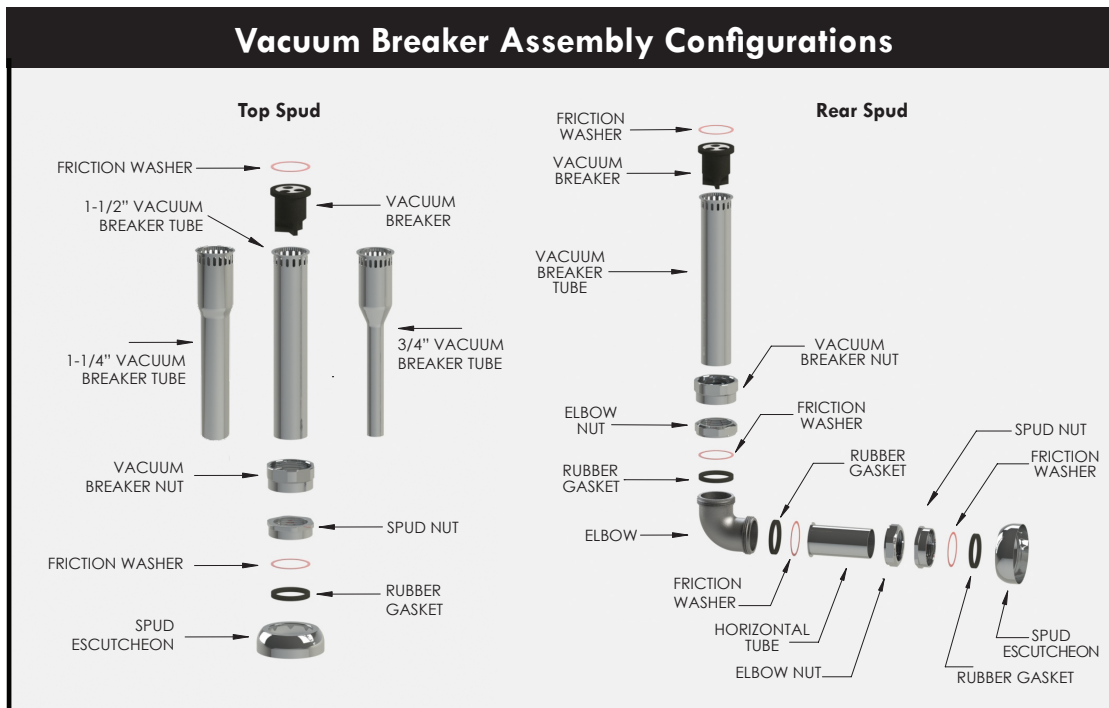

See I-CON Flush Connection Guide for details on available options.

Step 2

To remove battery module from control module, squeeze locking tabs and lift upwards.



Step 3

Remove screw and battery cover. Insert six (6) new AA batteries follow polarization markings. Reinstall battery cover and tighten screw. **NOTE:** Only use alkaline batteries of same brand and age.



Step 4

Reinstall battery pack onto control module.



ProLAST® T-SEAL & CONTROL MODULE INSTALLATION

Step 1

Insert ProLAST® T-Seal into flush valve body.



Step 2

Place square-profile O-ring into groove on bottom of control module. Place control module assembly onto flush valve body with front-facing directly towards user.



Step 3

Tighten locking ring by hand to flush valve body. Ensure control module assembly orientation has not changed.



CONTROL MODULE SETUP

Step 1

Turn on power switch.



Step 2

Adjust lockout and runtime with potentiometer as needed.



Step 3

Reinstall cover onto control module assembly. Insert screws and tighten by hand.



ADJUST CONTROL STOP

Step 1

Turn adjustment screw **COUNTERCLOCKWISE** 1/2 turn from closed position. Activate flush valve.

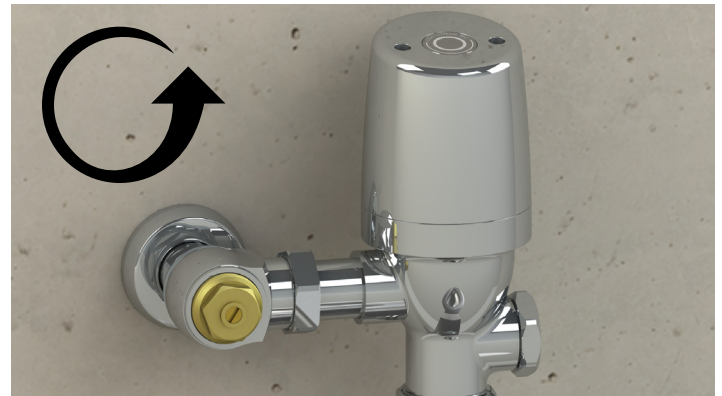

Step 2

To adjust flush valve, turn adjustment screw in small increments. Activate flush valve after each adjustment. The proper flow rate should completely cleanse fixture without splashing water outside of fixture.



Step 3

Reinstall control stop cap.



INSTALLATION COMPLETE

CARE OF CHROME PLATED SURFACES

Do not use commercial cleaning compounds to clean flush valve. Abrasive or chemical cleaners may dull the luster and attack finishes. Use mild soap and water and then dry with a clean nonabrasive cloth or towel. A microfiber cloth is recommended. Protect flush valve from any splattering when cleaning the floor, tile, or fixtures. **DO NOT USE ACID OR ALCOHOL BASED CLEANERS.**