

## KIT INCLUDES

- Slide Actuator
- Battery Compartment Tool
- Collar Wrench
- Actuator Seal
- Square Profile O-ring
- Trip Mechanism
- ProLAST® T-Seal
- COBALT® Cap



## TOOLS NEEDED



Battery Compartment Tool (Included)

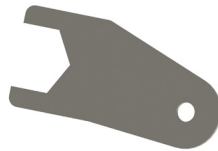

Collar Wrench (Included)



Strap Wrench

## PRIOR TO INSTALLATION

- All plumbing should be installed according to applicable state and local codes and regulations.
- Before installation of the I-CON flush valve, ensure the water closet or urinal fixture, drain line, and water supply line are properly installed.
- Water supply lines must be sized to allow for appropriate water flow for each fixture.
- Flush all water supply lines of any debris before making connections.
- Do not use pipe sealant or plumbing grease on any components or couplings with exception to the control stop inlet.
- A smooth jaw or strap wrench should be used for installation to prevent damage to the finish of the I-CON flush valve and components.

The I-CON flush valve is designed to operate at water pressures ranging from 15 to 100psi (103 to 689kPa). The fixture type determines the minimum pressure required for the valve. Most low-consumption water closets are designed to operate with a minimum flowing water pressure of 25psi (172kPa). Many building codes and the ASME A112.19.2 standard state maximum static water pressure as 80psi (552kPa).

## LIMITED WARRANTY

I-CON Systems (I-CON) warrants that its commercial manufactured products are made of first-class materials, are free from defects, and are made to withstand normal use when installed properly. Products have the following warranty periods: 3 years for COBALT®, COBALT Pro®, and COBALT Connect® faucets and flush valves and I-CON EDGE® gateways. 1 year for all other products and decorative finishes. The warranty period begins on the date of purchase. Products should be sent to I-CON at the customer's expense. I-CON will take a reasonable amount of time to determine if the product is defective and whether it will be repaired or replaced.

During the warranty period, items will either be (1) repaired at no charge using new replacement parts or (2) replaced with either a new similar product or one manufactured from new or serviceable used parts that is at minimum a functional equivalent to the original. The course of action will be determined at I-CON's discretion. Replacement products that are installed according to the instructions provided by I-CON will assume the remaining warranty of the original product. The limited warranty is only applicable to the product's materials and workmanship. No claims for labor, transportation, or other incidental or consequential costs will be allowed. No extended warranties are available. THE SOLE AND EXCLUSIVE REMEDY FOR ANY DEFECTIVE PRODUCT IS LIMITED TO REPAIRING OR REPLACING THE DEFECTIVE PRODUCT. Before installing and using products, the purchaser is responsible for determining the products' suitability and assumes all risks and liabilities related to the product. This warranty only applies to persons and organizations that purchase I-CON products directly from I-CON or an authorized I-CON representative for the purpose of resale. This warranty does not apply to the life of batteries or other consumables.

**EXISTING COMPONENT REMOVAL**

**Step 1**

Remove control stop cap.



**Step 2**

Turn adjustment screw **CLOCKWISE** to close control stop.



**Step 3**

Activate flush valve to relieve water pressure.



**Step 4**

Use strap wrench to remove flush valve cap. Remove all inner components. This commonly includes a diaphragm, trip mechanism, and plastic internal cap.



**Step 5**

Loosen actuator using the supplied collar wrench.



**Step 6**

Remove the existing actuator.



**INSTALLATION OF ELECTRONIC SIDE ACTUATOR**

**Step 1**

Install ProLAST® T-Seal, trip mechanism, and square-profile o-ring.



**Step 2**

Install I-CON flush valve cap onto flush valve body. Tighten by hand.

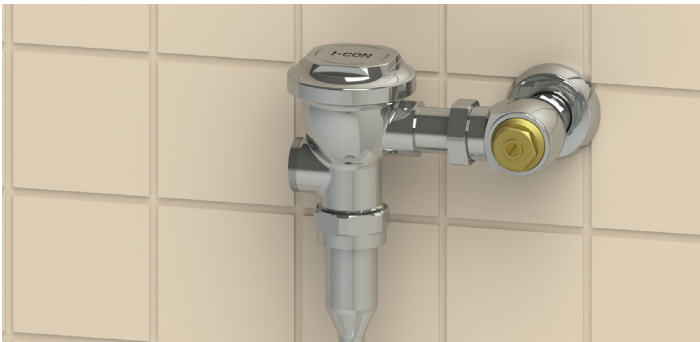

**Step 3**

Insert the electronic side actuator into the opening ensuring to use the actuator seal between.



**Step 4**

Tighten the side actuator using the supplied collar wrench.



**Step 5**

Using the supplied wrench loosen the battery compartment.

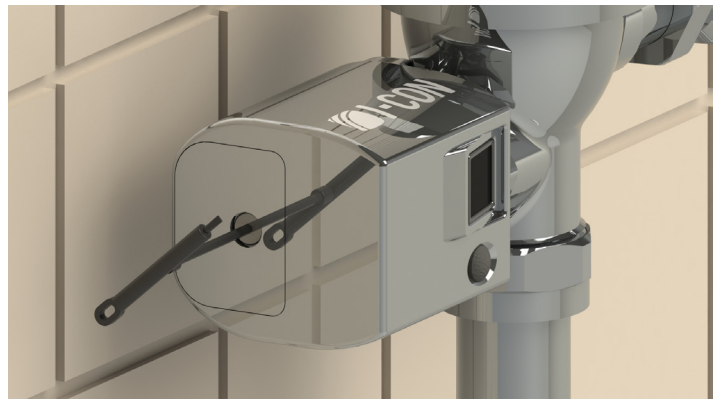

**Step 6**

Remove the battery compartment and install (4) C batteries.



## Step 7

Reinstall the battery compartment.

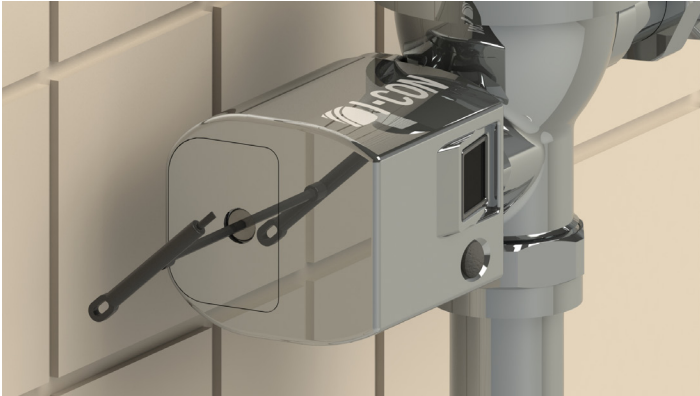

## ADJUSTING THE VALVE

### Step 1

Remove cover.

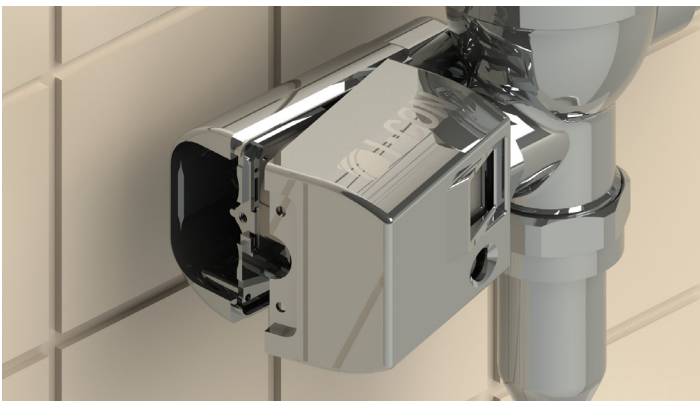

### Step 2

Remove the adjustment tool.

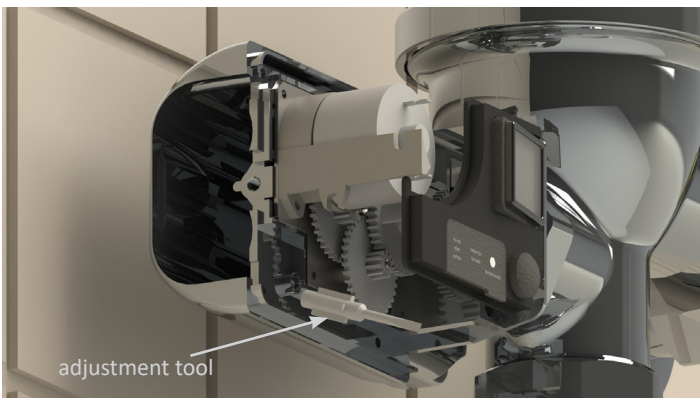

### Step 3

Open adjustment cover.

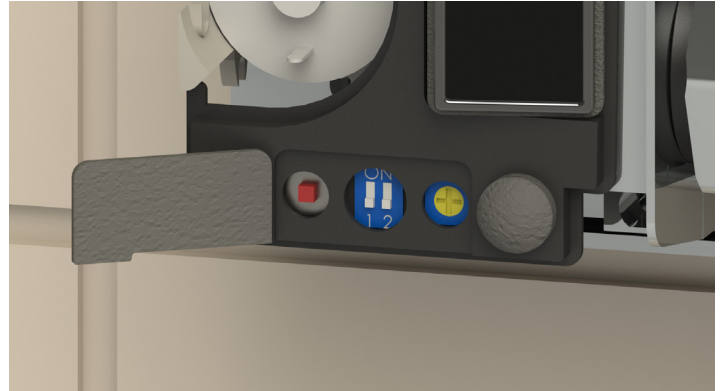

### Step 4

Adjust as desired. The button is the sensor range reset button. Switch one turns the 24-hour automatic flush feature on and off. Switch two turns the alert tone on and off. The potentiometer is the sensor range adjustment.



## ADJUSTING CONTROL STOP

### Step 1

Turn adjustment screw **COUNTERCLOCKWISE** 1/2 turn from closed position. Activate flush valve.

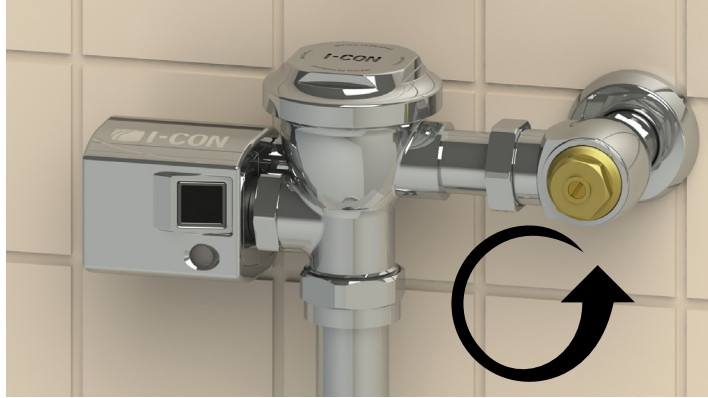

**Step 2**

To adjust flush valve, turn adjustment screw in small increments. Activate flush valve after each adjustment. The proper flow rate should completely cleanse fixture without splashing water outside of fixture.



**Step 3**

Reinstall control stop cap.



**INSTALLATION COMPLETE**

**CARE OF CHROME PLATED SURFACES**

Do not use commercial cleaning compounds to clean flush valve. Abrasive or chemical cleaners may dull the luster and attack finishes. Use mild soap and water and then dry with a clean nonabrasive cloth or towel. A microfiber cloth is recommended. Protect flush valve from any splattering when cleaning the floor, tile, or fixtures. **DO NOT USE ACID OR ALCOHOL BASED CLEANERS.**